

DSA Approved Shade Structures



Park Planet

DSA Approved Fabric & Metal Systems for California Schools

Standard and Custom Walkway Covers, Lunch Shelters, & More

PC Approved Shade Solutions

We offer models available in:

- Fabric Hips
- Metal Gable
- Metal Hips
- Metal Single Slope
- Metal Single Slope Walkway Cover
- Metal Gable Walkway Cover

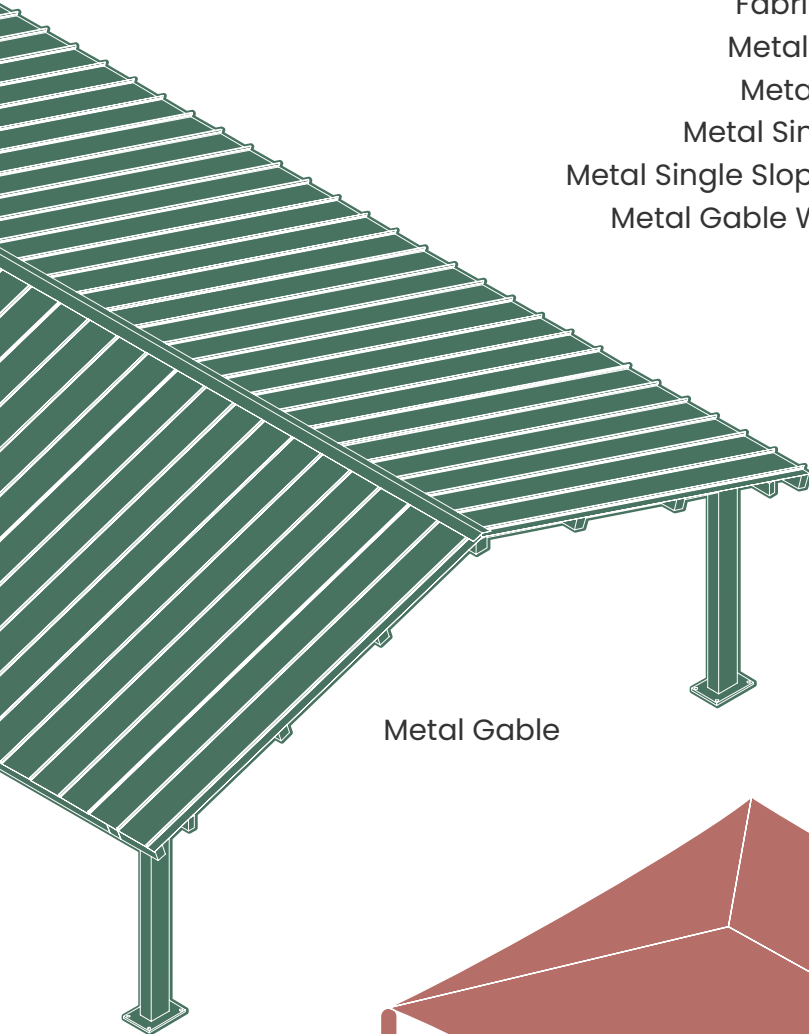

Metal Gable

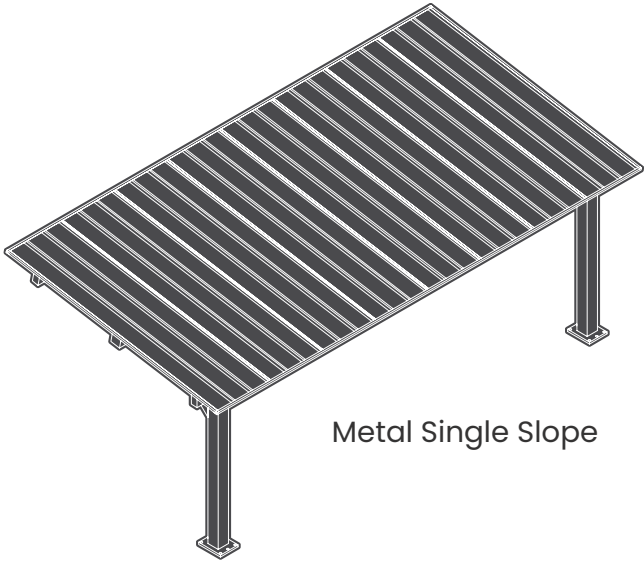

Metal Single Slope

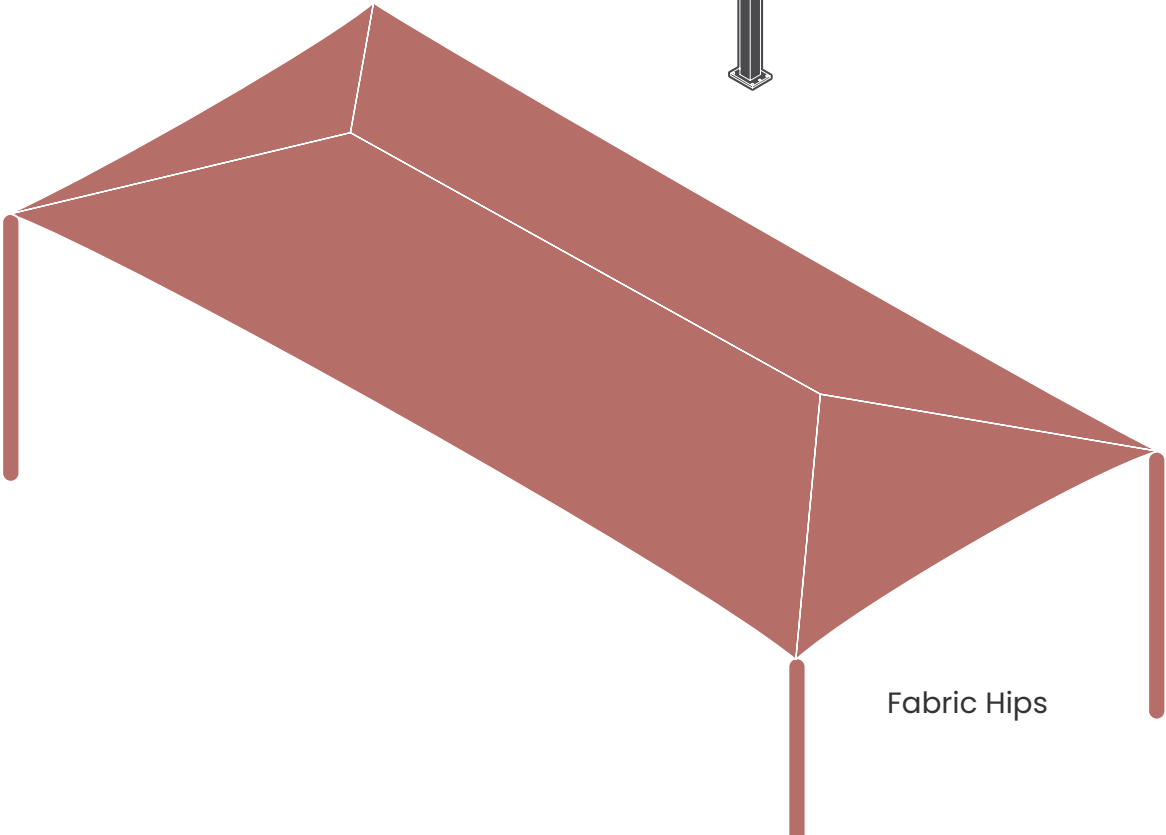

Fabric Hips

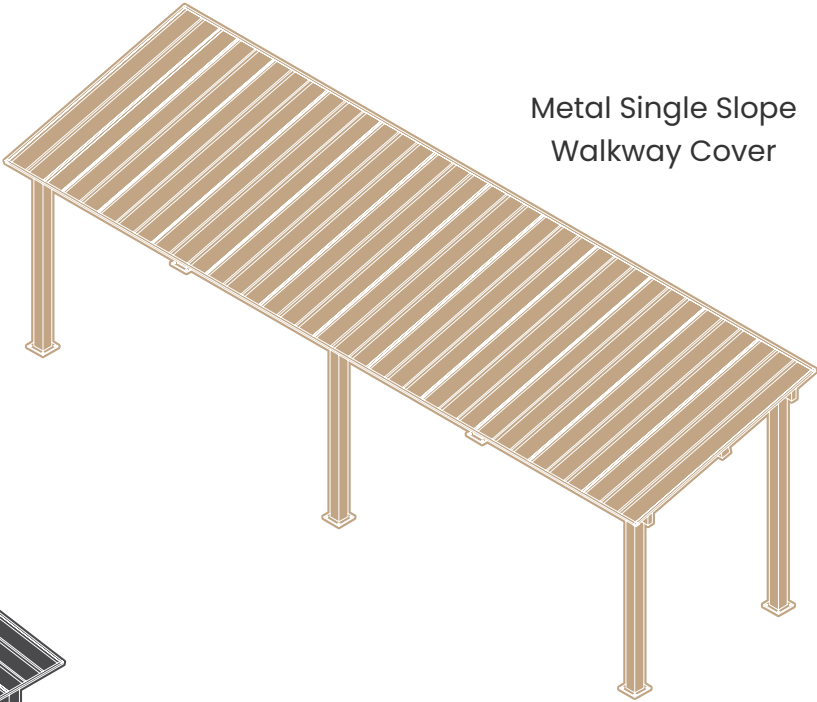

Metal Single Slope Walkway Cover

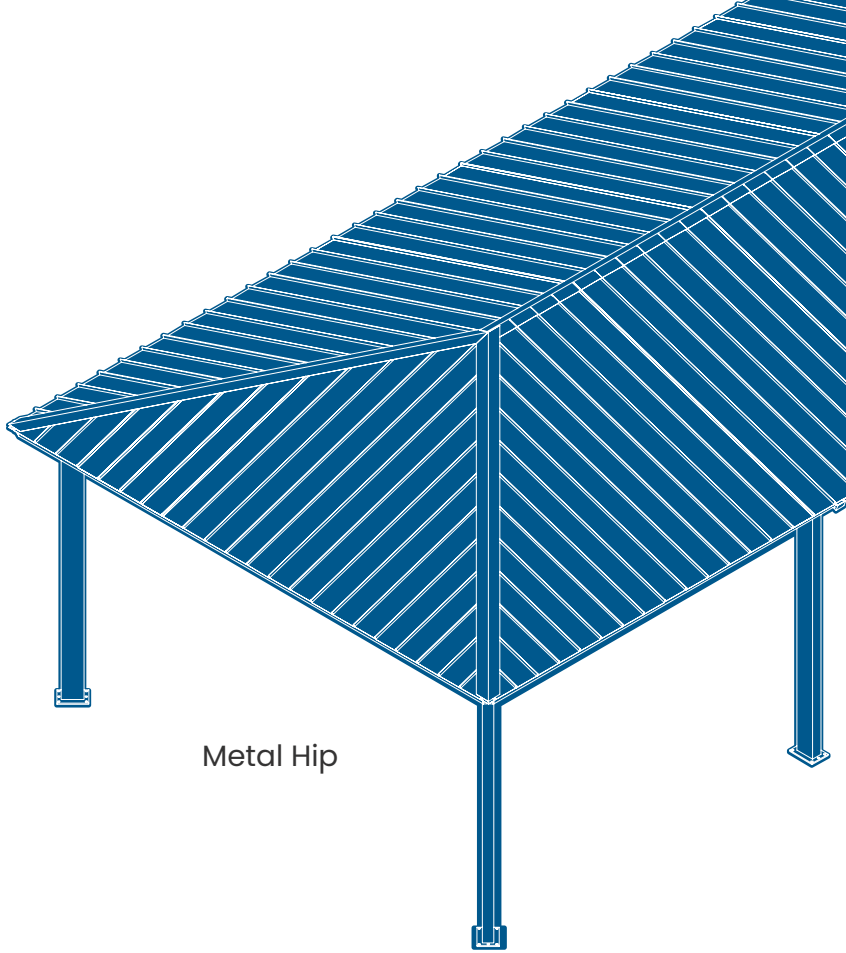

Metal Hip

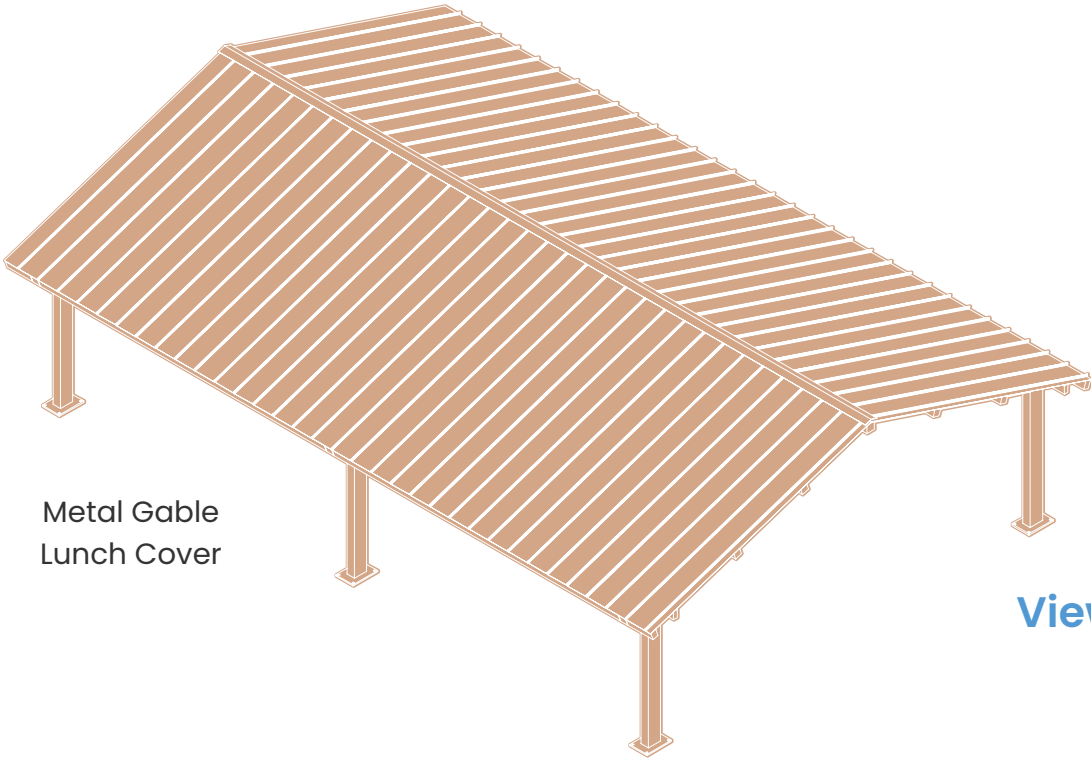

Metal Gable Lunch Cover

[View Plans & Sizes](#)



Unlimited Custom Options Compliant with DSA Requirements

We offer endless design capabilities to fit any space, on any budget.
No challenge is too big.

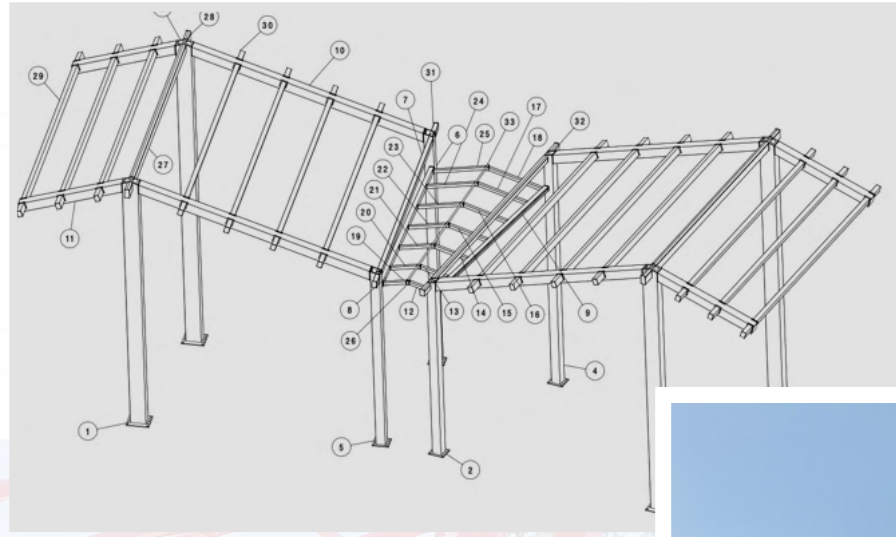

Specializing in Outdoor Environments Compliant with DSA Requirements

With the knowledge and experience to provide turnkey projects for all school shade systems and lunch shelters, Park Planet provides a seamless installation process, assisting with design and layout through completion.



Valley School Shelters

Premium Lunch Shelters and Walkway Covers

Featuring: Post Placement Flexibility on All Designs, Gutters and Downspouts, Spread Footing Option, Powder Coated Posts or Entire Structure, Solar Panel Ready, Multiple Roofing options, 20 & 30 lb. Snow Load, High Seismic Ratings Available



For Architects:

- If the shelter is for concentrated assembly gatherings and is greater than 2100 sqft., the shelter will be upgraded to Risk Category III.
- If the shelter is for unconcentrated assembly gatherings and is greater than 4500 sqft., the shelter will be upgraded to Risk Category III.
- If the structure is adjacent (<20') to a Risk Category III building, it may have to be classified as Risk Category III.
- If the shelter is adjacent to a sprinklered building, it may have to be sprinklered as well.
- If the structure is installed in an area with seismic SDS values between 0.92 and 1.0, and there is not an available geotechnical report, the structure will be classified as Risk Category III.



Manufactured in California, for California

We offer an extensive set of DSA Approved Plans that give architects and school facility administrators huge design flexibility.

Valley School Shelters / Post and Roof Color Options

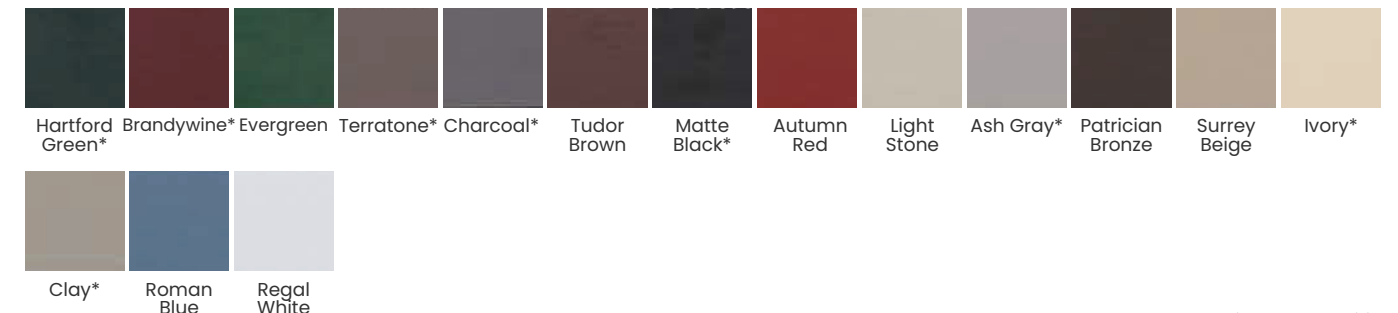

*Available at additional costs

Turning imagination into shade systems with a full range of high-quality shelters, gazebos, and outdoor structures.

Available Options:

- Standing Seam
- Mega Rib
- Multi Rib
- Engineered for Seismic Rating Up To 3.0
- Electrical Cutouts
- Solar Panel Attachments
- Rain Gutters and Downspouts
- Spread Footing



Built to Last

Features Include:

- All tube steel
- Minimally exposed fasteners
- All framing is epoxy coated & powder coated
- Custom DSA metal and fabric designs available

For Architects:

- If a geotechnical report is not available, then Soil Class 5 (worst case scenario) will be used to determine footing dimensions.
- If the structure is < 4000sqft, then a geotechnical/geohazard report is not required unless the structure is to be installed within an earthquake fault zone or seismic hazard zone.
- If the structure is >4000sqft, then geotechnical and geohazard reports will be required for DSA submission.

Gutter & Downspout Colors



Standard Steel Roof Colors

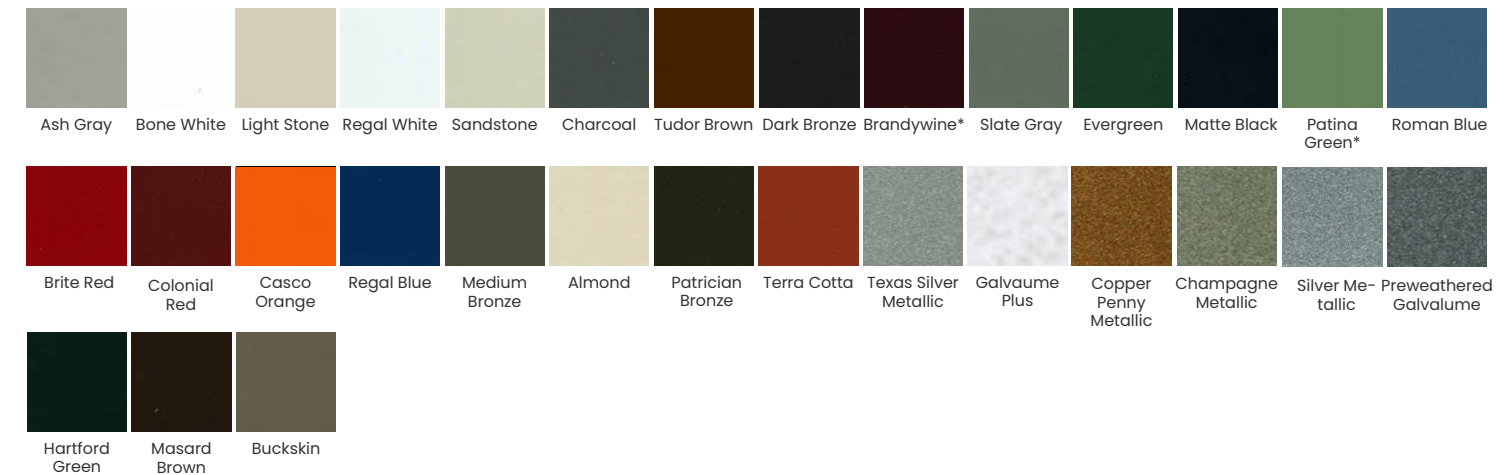

Standard Powder Coat Colors

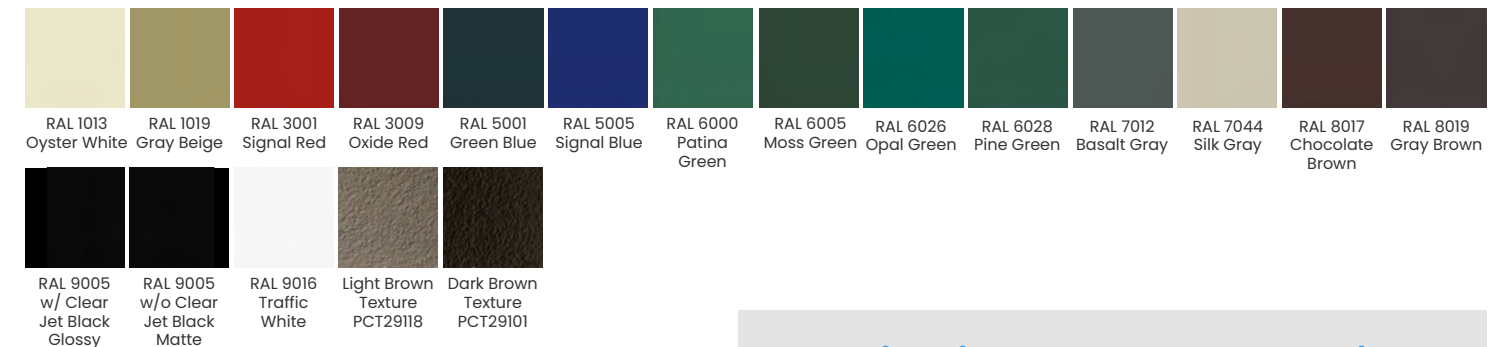

PC Hip Sizes

30 x 44, 64 or 84
40 x 44, 64 or 84

PC Gable Sizes

30 x 24, 44, 64 or 84
40 x 24, 44, 64 or 84

**Available in 24ga roofing only*



Custom Canopies

Our Leading Made-In-America Manufacturer of DSA Shade Canopies, Sails, and Umbrellas

Features Include:

- All standard sizes include 4 posts
- 98% UV blocking & 25 degrees cooler
- Gatorshield steel with triple-layer zinc coating for rust and corrosion resistance
- Can be linked together in one direction for a maximum of 6000 square feet
- Alnet fire block fabric
- DSA & CA fire marshall approved post pads available
- All steel frames come standard with powder coating
- Suitable for locations with <105mph wind speed
- <1.43 Seismic SDS
- A soil compressive strength >1500psi.



For Architects:

- If the canopy is >1600 sqft. and <4000 sqft., a Geotech report is required when the project is submitted to DSA to verify that there is no liquefaction.
- If the canopy is >4000 sqft., then a Geotechnical/Geohazard report is required upon DSA submittal.

Powder Coat Options

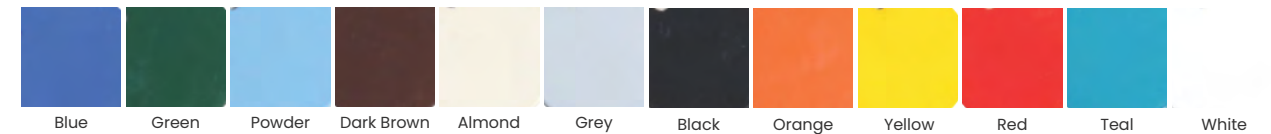

CA Fire Marshall Approved Fabric

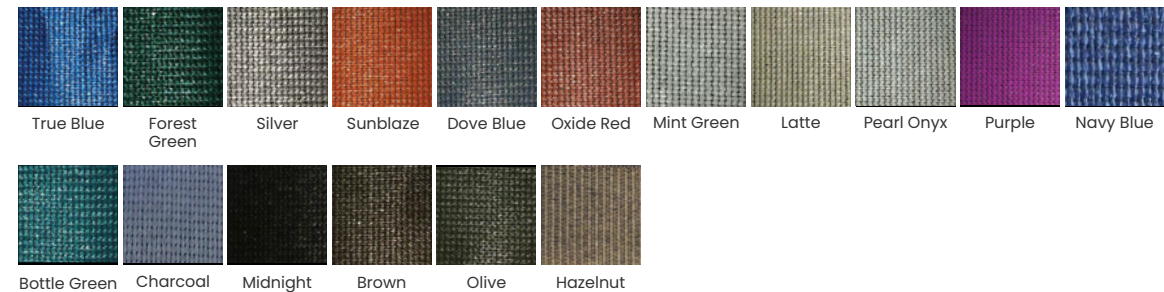

Completed DSA Projects

Our work speaks for itself

Park Planet's DSA approved products make inspections simple, fast, and cost-effective.



Custom Projects

BUILDING C
UPPER CLASSROOM WING
DSA #21211

BUILDING H
TOILET BUILDING
DSA #01-101851

BUILDING F
CLASSROOMS
8660

A.03 A.04 A.05 A.07 A.08 A.20

Typical Project Workflow

Our Team is Experienced with Seismic Zones, Inspections, and Testing Procedures

Park Planet is experienced with seismic zones, inspection, and testing procedures. With the convenience of pre-approved plans, you can start your project immediately while Park Planet works with highly trained crews to complete your project without sacrificing quality.



Before Your Structure is Ordered:

1. Hire an architect to submit your project to DSA.
2. We give the approved PC plan to your architect and coordinate project details.
3. Your architect makes an appointment with DSA and presents the plans and documentation required.
4. Hire an Inspector of Record (IOR) and a Laboratory of Record (LOR). Our team will point you to a trusted inspector and contractor depending on the location of your project.
5. DSA approves your project, we obtain all contact information, and place the order for your structure.

Installation:



Our installers coordinate onsite inspections with the Inspector of Record (IOR) and test samples with the Laboratory of Record (LOR)



Installation is complete



We provide a signed DSA Form 6C



Your architect closes out the project with DSA

Purchasing Contracts & Other Products

Other Products from Park Planet

Park Planet is a premium outdoor equipment dealer that provides full-service installations for seamless turnkey projects, from DSA shade solutions to playground equipment and park furnishings.



Streamline Your Process with Us

Let's keep things simple. We help you cut through the red tape and avoid the lengthy process of writing specs, issuing RFPs and jumping through hoops that come up along the way. Our contracts help eligible groups purchase from participating vendors to reduce costs and eliminate lengthy bid processes.





Park Planet

Email us:

info@parkplanet.com
sales@parkplanet.com

Call us:

Toll Free: 877-473-7619

Visit our website:

www.parkplanet.com

